

TEAM LOSI SET UP SHEET EIGHT

Name: R/C Car Magazine / Drake & Amezcua Date: _____ Event: _____
 City: _____ State: _____ Track: Pro-Line Test Track
 Track Conditions: Indoor Tight Smooth Hard Packed Blue Groove Wet Low Bite High Bite
 Outdoor Open Rough Loose/Loamy Dry Dusty Med Bite Other _____

Front Suspension
 Toe: +2 deg.
 Ride Height: 28mm
 Camber: -1 deg.
 Caster: 20-deg
 Sway Bar: 2.3mm
 Piston/Oil: #54 piston / 45wt Losi oil
 Spring: Silver
 Limiter/Droop: Use droop screw to adjust shock length
 Overall Shock Length: 95mm
 Steering Ackerman: Long
 Bump Steer: Down
 Camber Link: #2
 Shock Location: #2 / Inside on arm
 Front Diff Fluid: 5000
 Receiver Battery Type: _____
 Center Diff Fluid: 7000

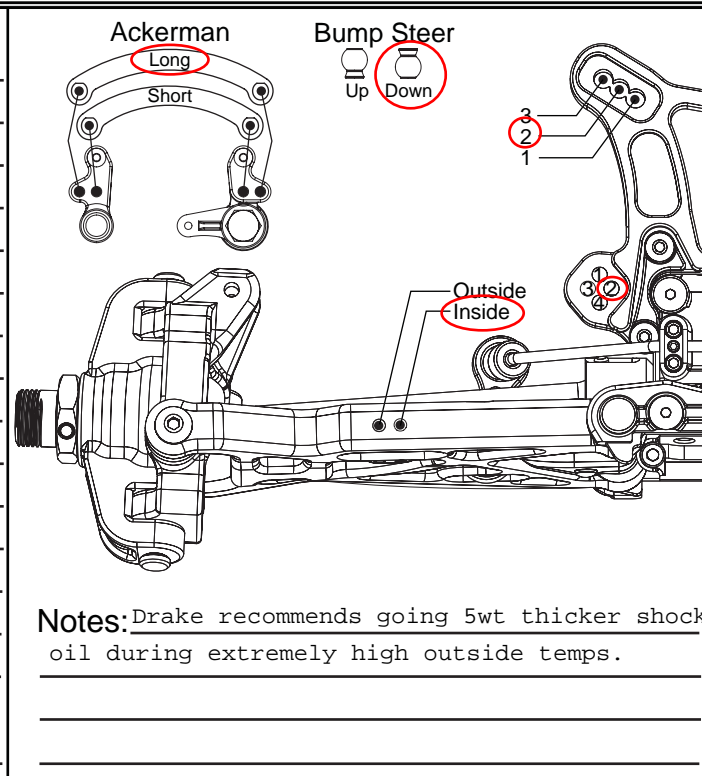

Rear Suspension
 Toe: 3-deg
 Anti-Squat: 3-deg
 Ride Height: 29mm
 Camber: -2 deg
 Rear Hub Spacing: Back
 Sway Bar: 2.5mm
 Piston/Oil: #55 / 37.5 Losi oil
 Spring: Green
 Limiter/Droop: Use droop screw to adjust shock length
 Overall Shock Length: 106mm
 Camber Link: #4 / B on hub
 Shock Location: #2 / inside on arm
 Rear Diff Fluid: 2000

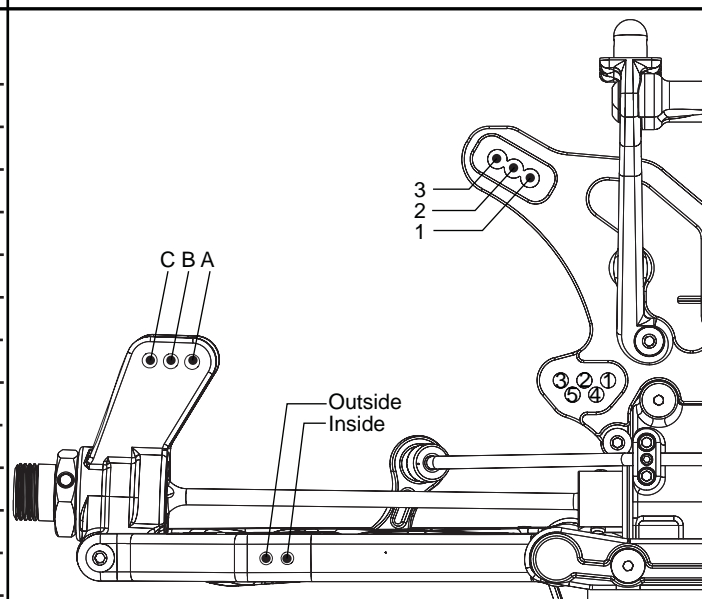

Engine
 Engine: _____ Fuel: _____
 Glow Plug: _____ Head Clearance: _____
 Pipe/Header: _____ Gearing: _____

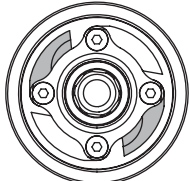
Clutch

Clutch Shoes and Springs Info
 Box stock set up

Tires

Type	Compound	Insert
Front: _____	_____	_____
Rear: _____	_____	_____
Notes: Very high-speed, open track set-up.		